

Z213.720-1===

Technical drawing

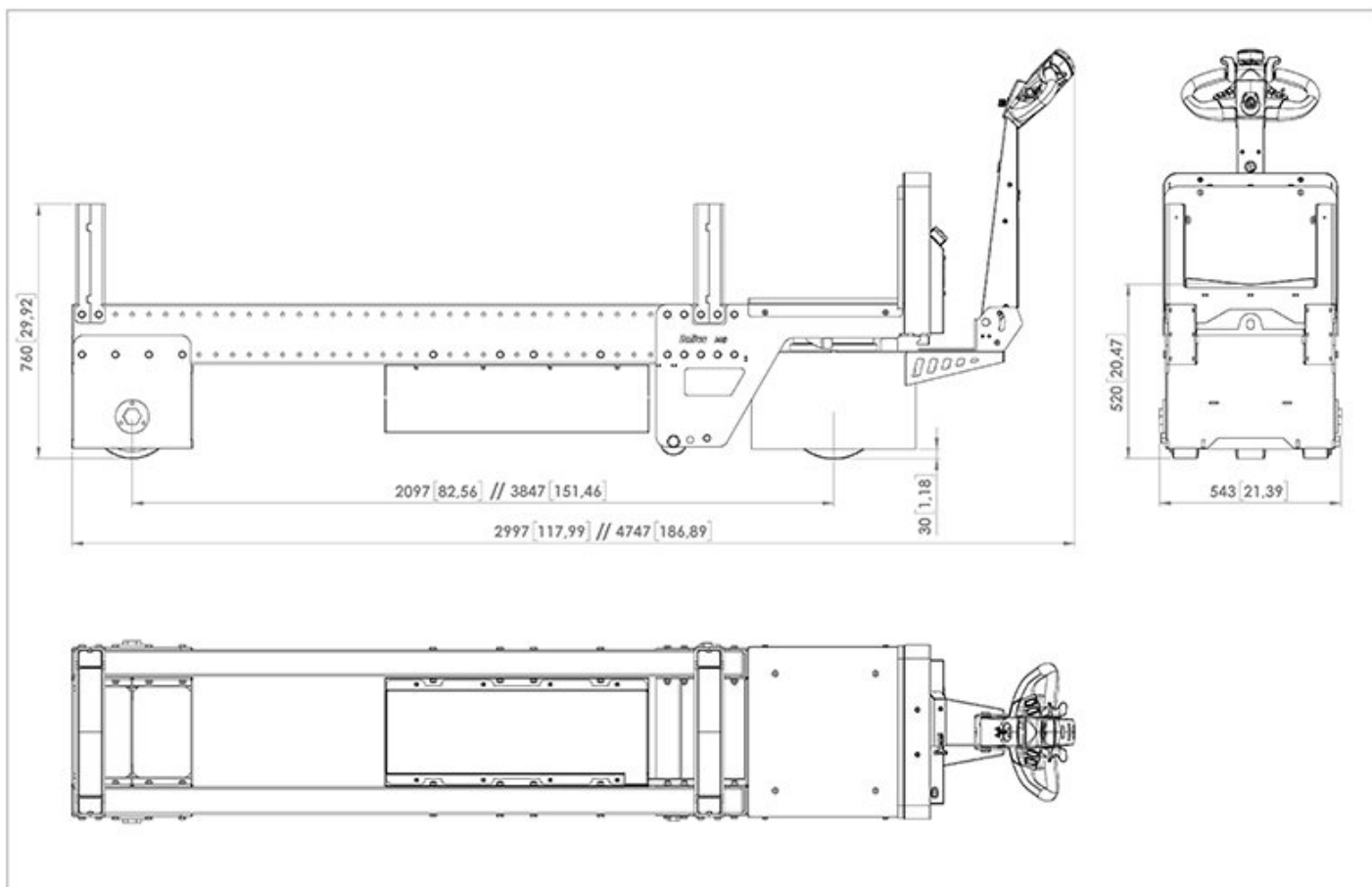

Technical data

1. Characteristics

Réf.no.	Description	U.M.	Valeur
1.01	Model number		Z213.720-1===
1.02	Model name		M8
1.03	Manufacturer		Zallys
1.04	Operator		Pedestrian
1.05	Power unit		Electric
1.07	CE certification		
1.08	Plant tension	V	24
1.09	Nominal power	kW	1,50

1. Frame characteristics

Réf.no.	Description	U.M.	Valeur
1.80	Frame made of		Steel
1.82	Anti-Corrosion Treatment (on customer demand only)		Cataphoresis
1.83	Frame treatment		Polyester powder coating

2. Safety data

Réf.no.	Description	U.M.	Valeur
2.01	Dead man safety system		Sensor on tiller head
2.02	Emergency reverse button		On tiller head
2.03	Emergency stop device		
2.04	Creep speed device		Button on tillerhead
2.06	Power supply disconnection device / Emergency stop		Detachable power connector
2.10	Acoustic signaling		claxon / cicalino
2.11	Drive controls		Maintained action switch
2.20	Handarm vibration	m/s ²	<2,5
2.22	Noise level at operator's ears	dB	<70

3. Performances

Réf.no.	Description	U.M.	Valeur
3.01	Max. forward speed	km/h	4,0

Réf.no.	Description	U.M.	Valeur
3.02	Max. backward speed	km/h	4,0
3.07	Max.load capacity on flat ground	kg	3.000
3.28	Stopping distance in deceleration (without load)	m	1,5

4. Drive controls

Réf.no.	Description	U.M.	Valeur
4.01	Type of control		Tillerhead
4.02	Type of start control		Butterfly lever
4.04	Speed control		5 speed button assembled on the tiller head (optional)

5. Standard battery specifications

Réf.no.	Description	U.M.	Valeur
5.01	Batteries		4
5.02	Batteries type		Traction AGM batteries
5.03	Battery voltage	V	6
5.04	Nominal Capacity 5 h	Ah	200
5.05	Nominal Capacity 20 h	Ah	240
5.06	Weight of each battery	kg	32

6. Available chargers

Réf.no.	Description	U.M.	Valeur
6.40	Standard voltage	V	220/240
6.41	Multitension	V	110/240
6.42	Plug		In use in the country of destination

6. Technical data of standard charger

Réf.no.	Description	U.M.	Valeur
6.01	Battery charger		External - high frequency
6.02	Input voltage	V	230
6.03	Input Frequency	Hz	50-60

7. Drive motor

Réf.no.	Description	U.M.	Valeur
7.03	Engine		Electric
7.04	Electricity		Alternating current
7.05	Engine voltage	V	24

8. Technical data

Réf.no.	Description	U.M.	Valeur
8.01	Transmission system		Mechanical
8.02	Transmission lubrication		In oil bath
8.05	Traction		Front-wheel drive
8.06	Service brake		Electronic
8.08	Parking brake		Electro-Mechanical

9. Weight

Réf.no.	Description	U.M.	Valeur
9.01	Weight without batteries	kg	339
9.11	Weight incl. 200/240A AGM batteries	kg	477

10. Dimensions

Réf.no.	Description	U.M.	Valeur
10.01	Length	mm	3.095,00
10.02	Width	mm	543,00
10.03	Height of start control	mm	1.166,00
10.14	Wheelbase	mm	2.097,00
10.15	Turning circle	mm	2.800,00
10.16	* with tiller in vertical position		
10.50	**For further details please click on technical draws		

11. Standard wheels

Réf.no.	Description	U.M.	Valeur
11.01	Drive wheels		1
11.04	Castor wheels		2
11.05.1	Tyre for fixed wheels		Polyurethane (oil resistant)
11.05.2	Tyre for motor wheel		Polyurethane (oil resistant)
11.13	Drive tyres size		“ 300 X 100
11.18	Castor wheels dim.		“ 250



••• the passion for moving